



US007773460B2

(12) **United States Patent**
Holt

(10) **Patent No.:** **US 7,773,460 B2**
(45) **Date of Patent:** **Aug. 10, 2010**

(54) **MEDICATION REGIMEN COMMUNICATOR APPARATUS AND METHOD**

(76) Inventor: **Lindsay Holt**, 135 S. 300 West, Bountiful, UT (US) 84010

(*) Notice: Subject to any disclaimer, the term of this patent is extended or adjusted under 35 U.S.C. 154(b) by 2041 days.

(21) Appl. No.: **10/287,256**

(22) Filed: **Nov. 4, 2002**

(65) **Prior Publication Data**

US 2004/0088132 A1 May 6, 2004

(51) **Int. Cl.**

G04B 47/00 (2006.01)
G04B 45/00 (2006.01)
G09D 3/00 (2006.01)
G09F 9/00 (2006.01)

(52) **U.S. Cl.** **368/10**; 368/41; 368/223; 40/107; 116/308; 283/2; 283/115

(58) **Field of Classification Search** 368/280, 368/107, 10, 28, 41, 223; 283/81, 1, 2, 3, 283/4, 115, 900; 40/107, 110, 446; 116/298, 116/308

See application file for complete search history.

(56) **References Cited**

U.S. PATENT DOCUMENTS

630,822 A *	8/1899	Bates	283/81
1,448,698 A *	3/1923	Murdoch	283/115
1,533,297 A *	4/1925	Aller	368/88
1,588,964 A *	6/1926	Hutchins	283/115
1,837,707 A *	12/1931	Follows	116/308
2,040,119 A *	5/1936	Baxter	116/308
3,921,568 A *	11/1975	Fish	116/308
3,964,196 A *	6/1976	Ureta	40/107
4,295,664 A *	10/1981	Cutting	283/115
4,490,711 A	12/1984	Johnston	340/309.4
4,523,852 A	6/1985	Bauer	356/421
4,614,360 A *	9/1986	Sheehan et al.	281/45

4,703,017 A	10/1987	Campbell et al.	436/501
4,786,596 A	11/1988	Adams	435/28
4,799,712 A *	1/1989	Biava et al.	462/67
4,815,767 A *	3/1989	Lambert	283/67
4,849,948 A	7/1989	Davis et al.	368/10
4,877,580 A	10/1989	Aronowitz et al.	422/58
5,031,937 A *	7/1991	Nellhaus	283/52.1
5,102,169 A *	4/1992	Mayfield	283/115
5,207,746 A	5/1993	Jones	283/81
5,261,702 A *	11/1993	Mayfield	283/115
5,271,172 A *	12/1993	Ureta	40/107
5,386,990 A *	2/1995	Smith	473/131
5,393,100 A	2/1995	Coe	283/115
5,431,450 A	7/1995	Coleman	283/62
5,591,645 A	1/1997	Rosenstein	436/514
5,646,913 A *	7/1997	Quesenberry	368/223

(Continued)

OTHER PUBLICATIONS

www.dictionary.com definition of analog, Dec. 28, 2009.*

Primary Examiner—Vit W Miska

(74) Attorney, Agent, or Firm—Pate Pierce & Baird

(57) **ABSTRACT**

A “medication communicator” chart is used as a teaching tool to educate patients and to schedule events corresponding to a prescribed medication regimen. The “medication communicator” chart includes a scheduling graph having the shape of a 12-hour or 24-hour analog clock. The scheduling graph is divided into regions corresponding to each hour of a day for scheduling event information. Fields, on the “medication communicator” chart, are receptive to labels communicating information corresponding to numerous medications in the medication regimen. Timing indicators may be applied to the regions of the scheduling graph to indicate consumption or application times of each of the medications.

16 Claims, 12 Drawing Sheets

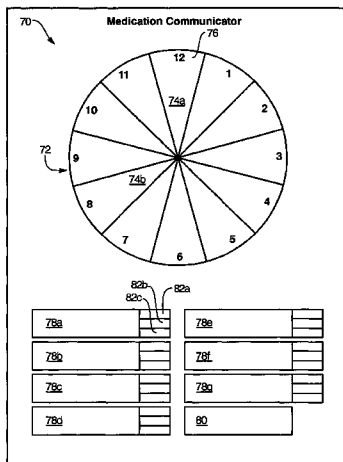

US 7,773,460 B2

Page 2

U.S. PATENT DOCUMENTS						
			6,130,100	A	10/2000	Jobling et al. 436/518
5,758,096	A	5/1998	Barsky et al.			
			6,169,707	B1	1/2001	Newland 368/10
5,954,641	A	9/1999	Kehr et al.			
			6,303,081	B1	10/2001	Mink et al. 422/61
5,958,536	A	9/1999	Gelsinger et al.			
			6,304,849	B1	10/2001	Uecker et al. 705/3
5,995,938	A *	11/1999	Whaley 705/3			
			6,376,195	B1	4/2002	Mapes 435/7.1
6,018,289	A	1/2000	Sekura et al.			
			6,574,165	B2 *	6/2003	Sharma et al. 368/10
6,085,752	A	7/2000	Kehr et al.			
			2001/0023548	A1 *	9/2001	Bundy 40/446
6,102,855	A	8/2000	Kehr et al.			
			2007/0287140	A1 *	12/2007	Liebowitz 434/304

* cited by examiner

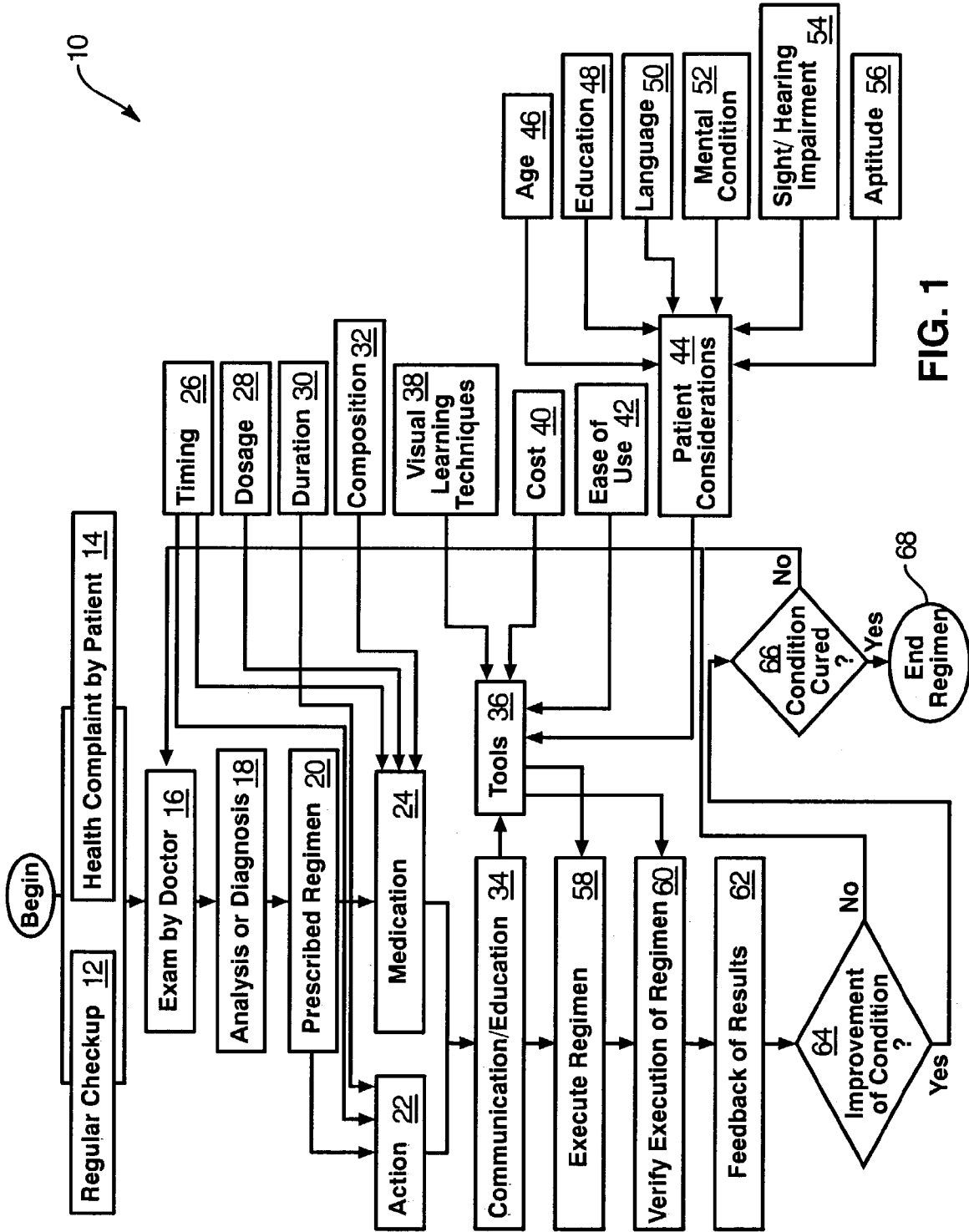

FIG. 1

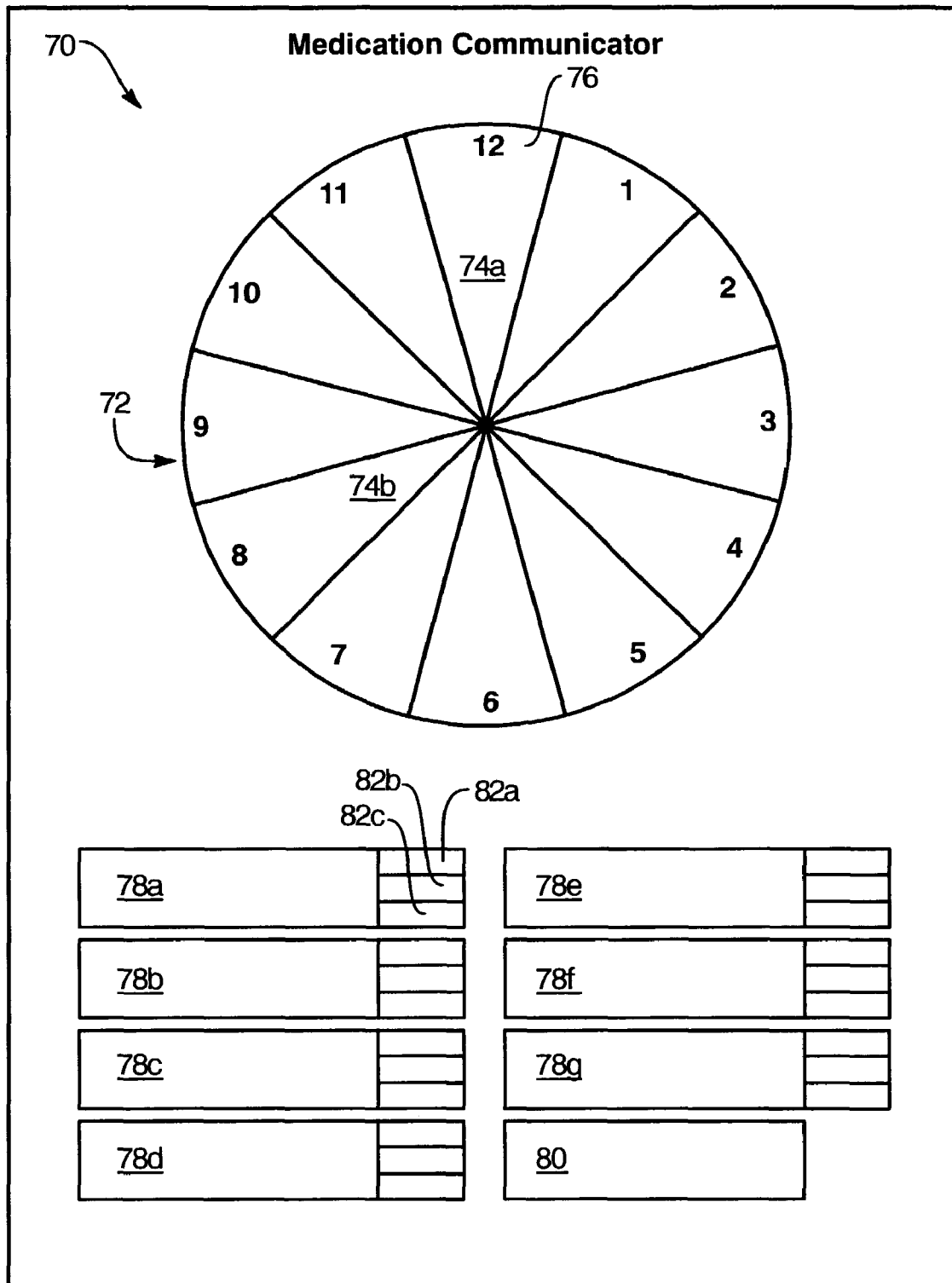

FIG. 2

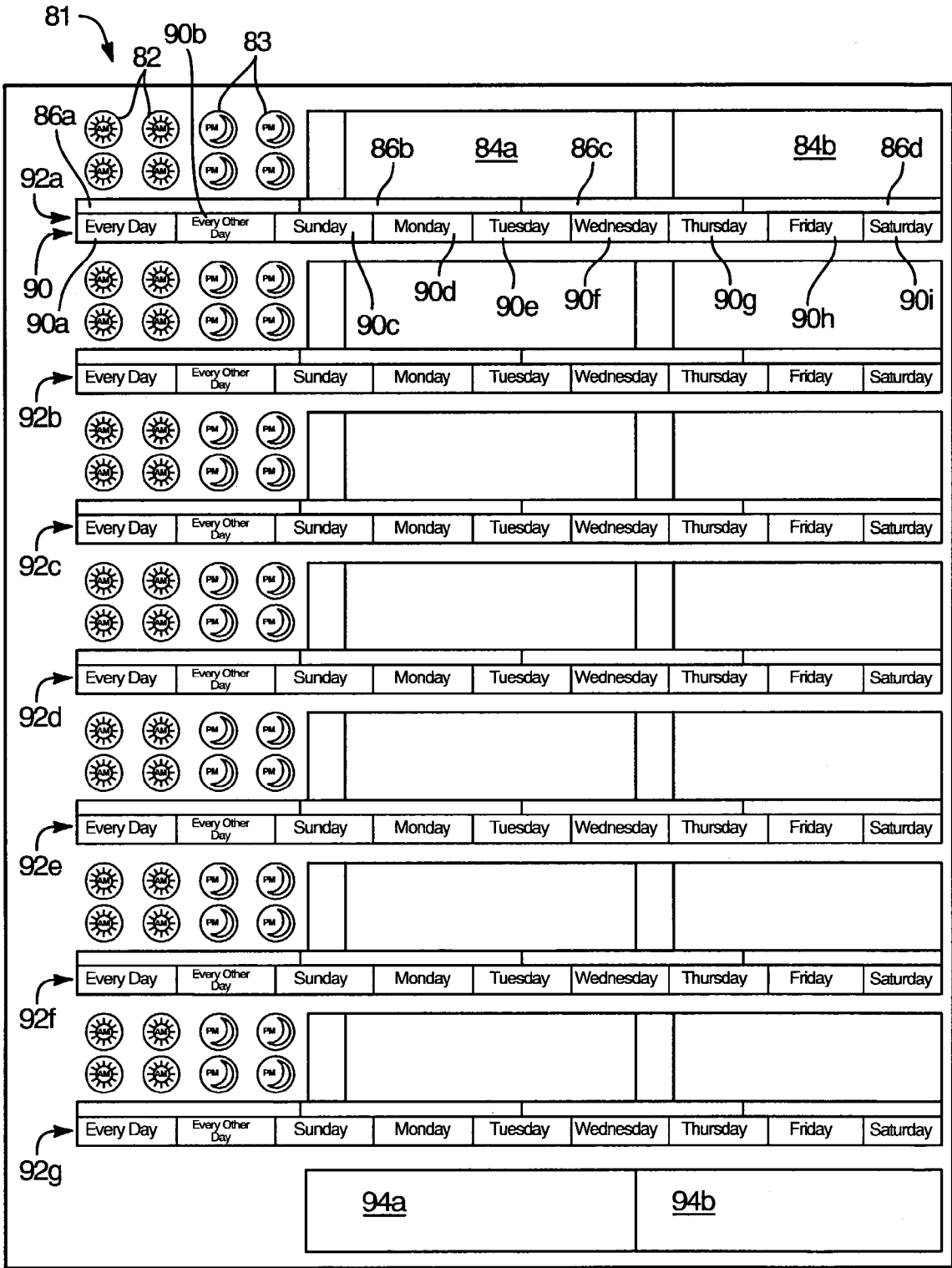

FIG. 3

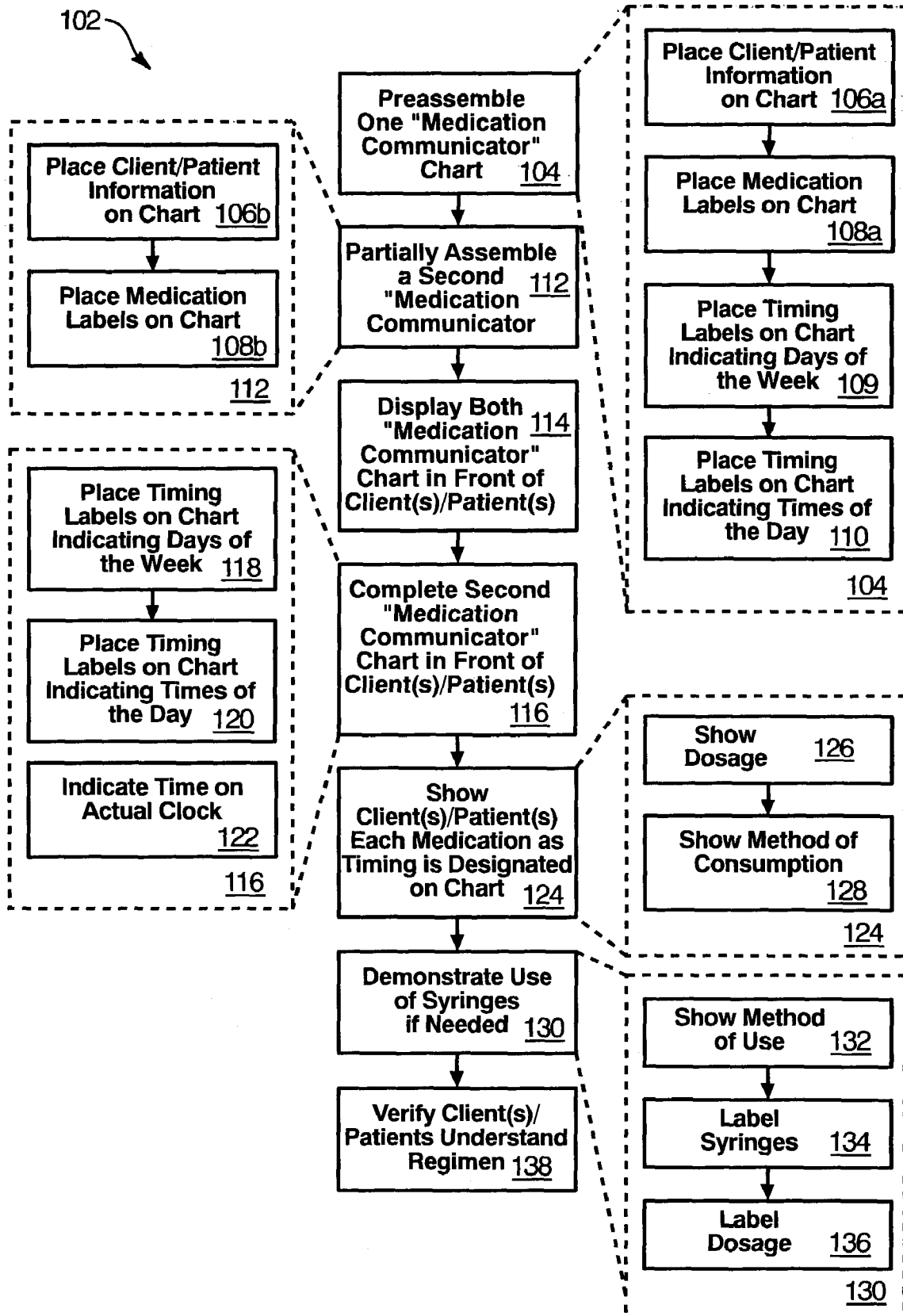

FIG. 5

140

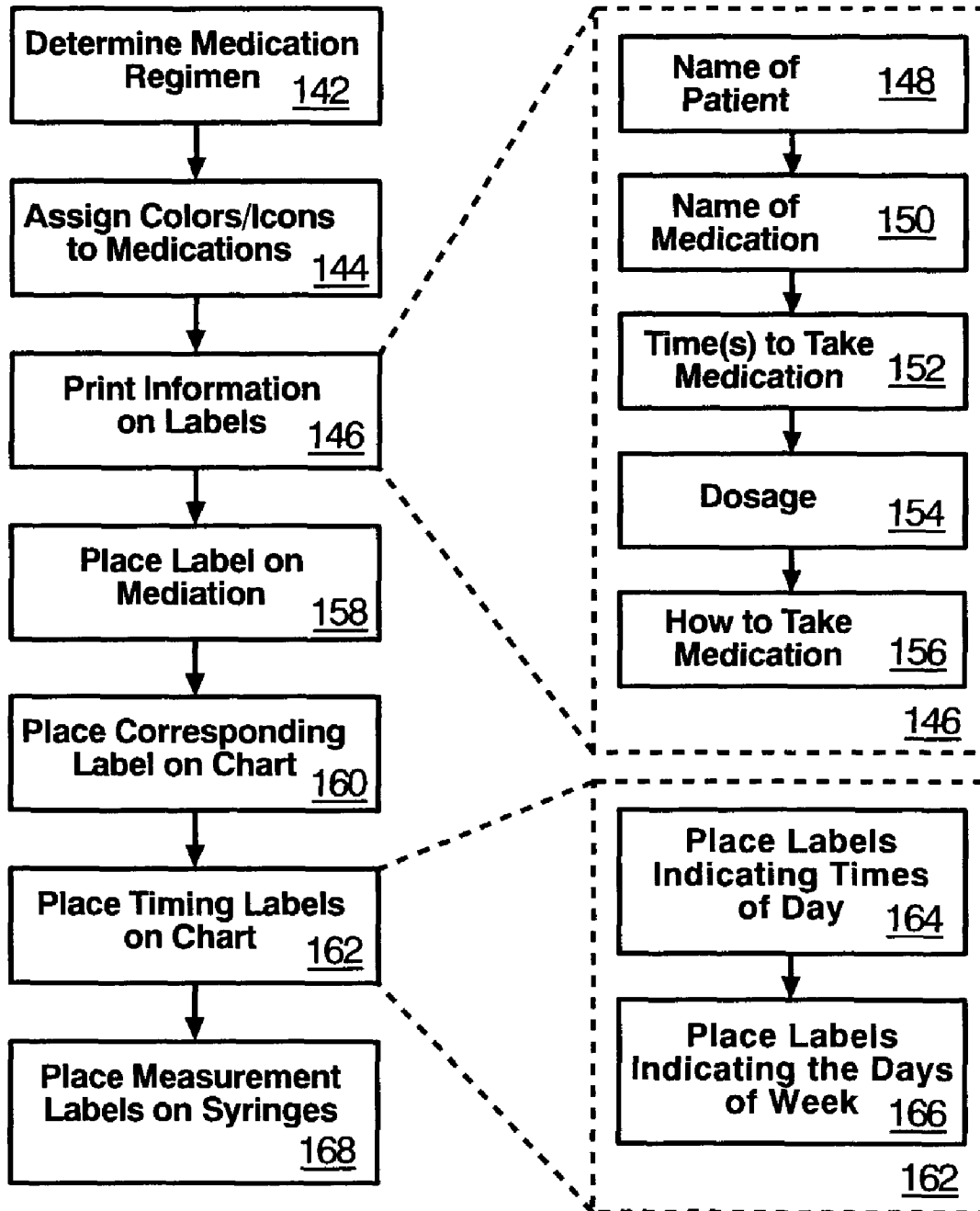

FIG. 6

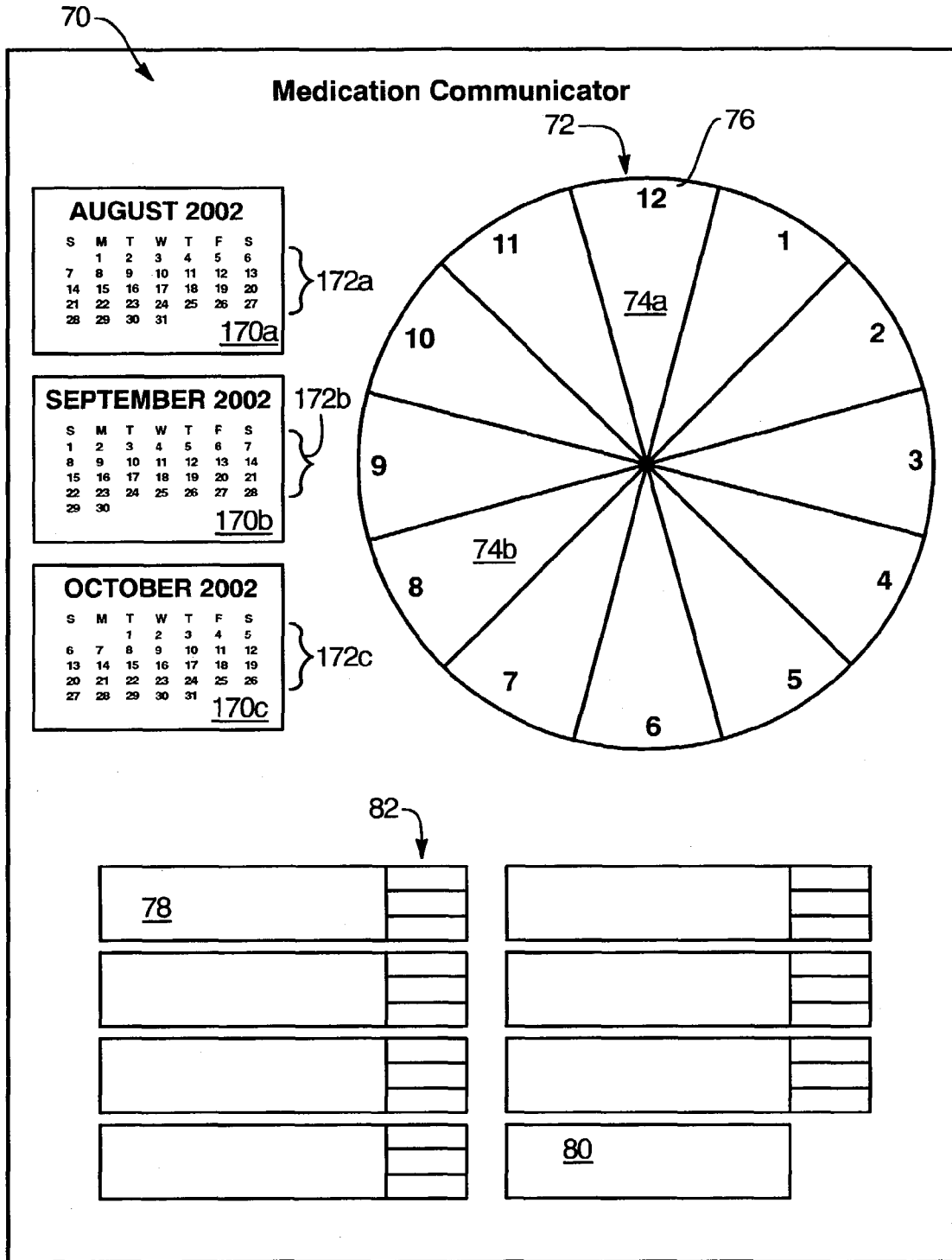

FIG. 7

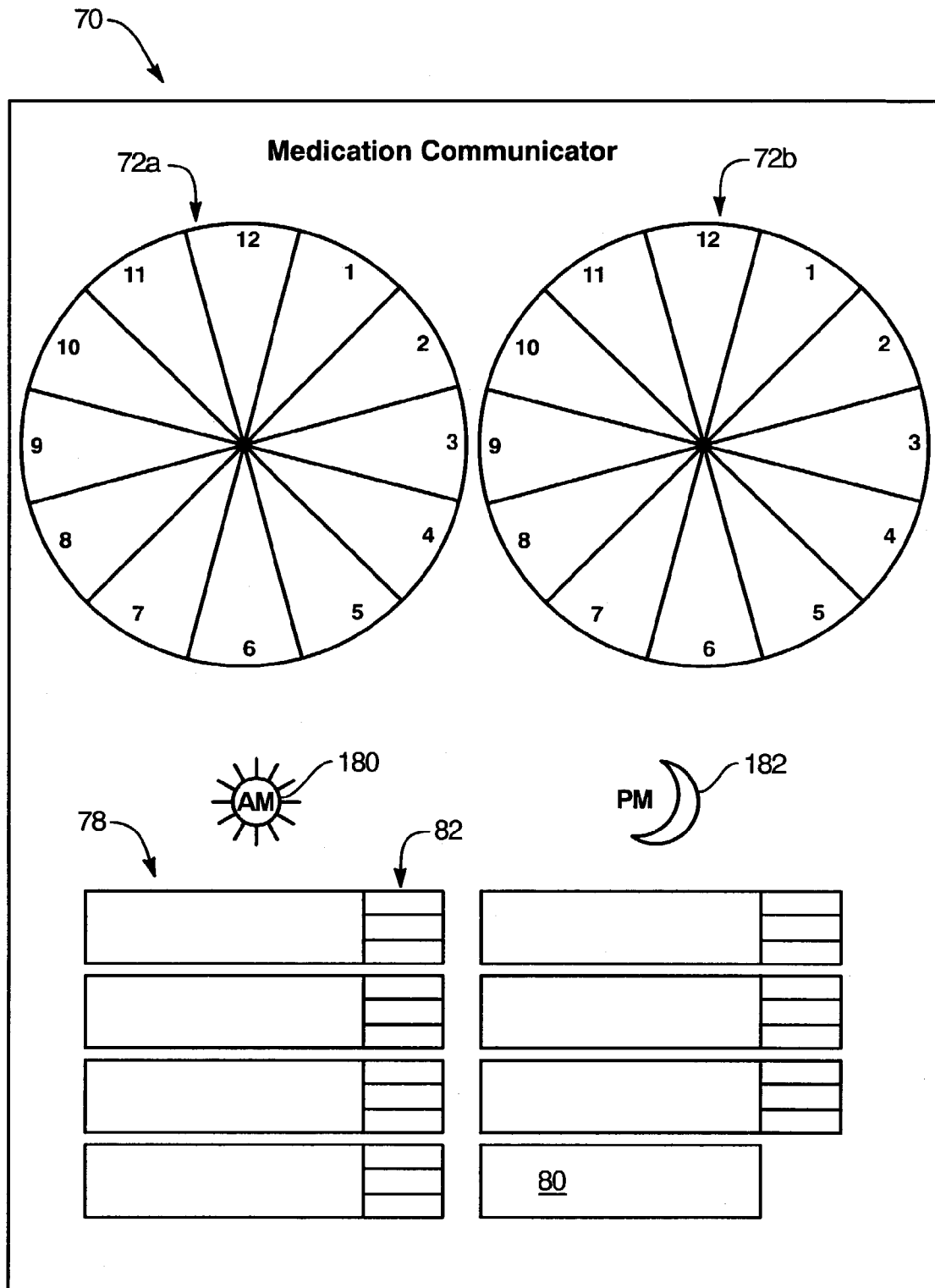

FIG. 9

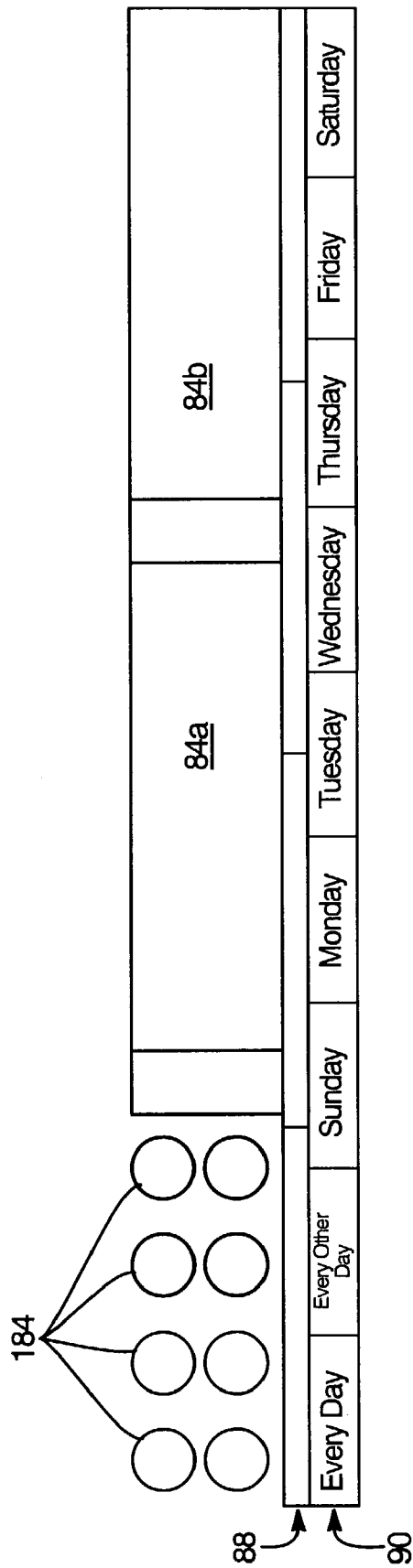

FIG. 10

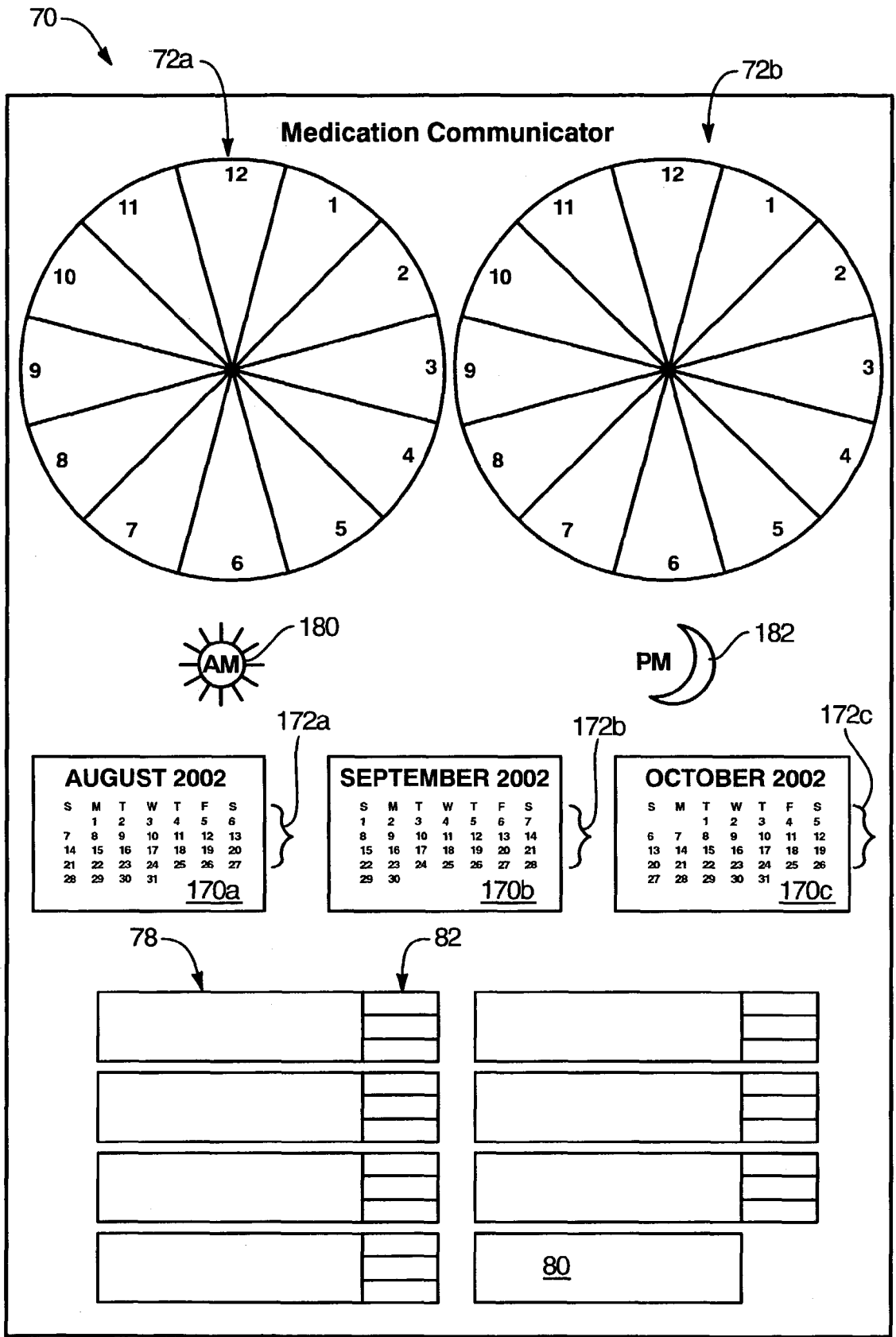

FIG. 11

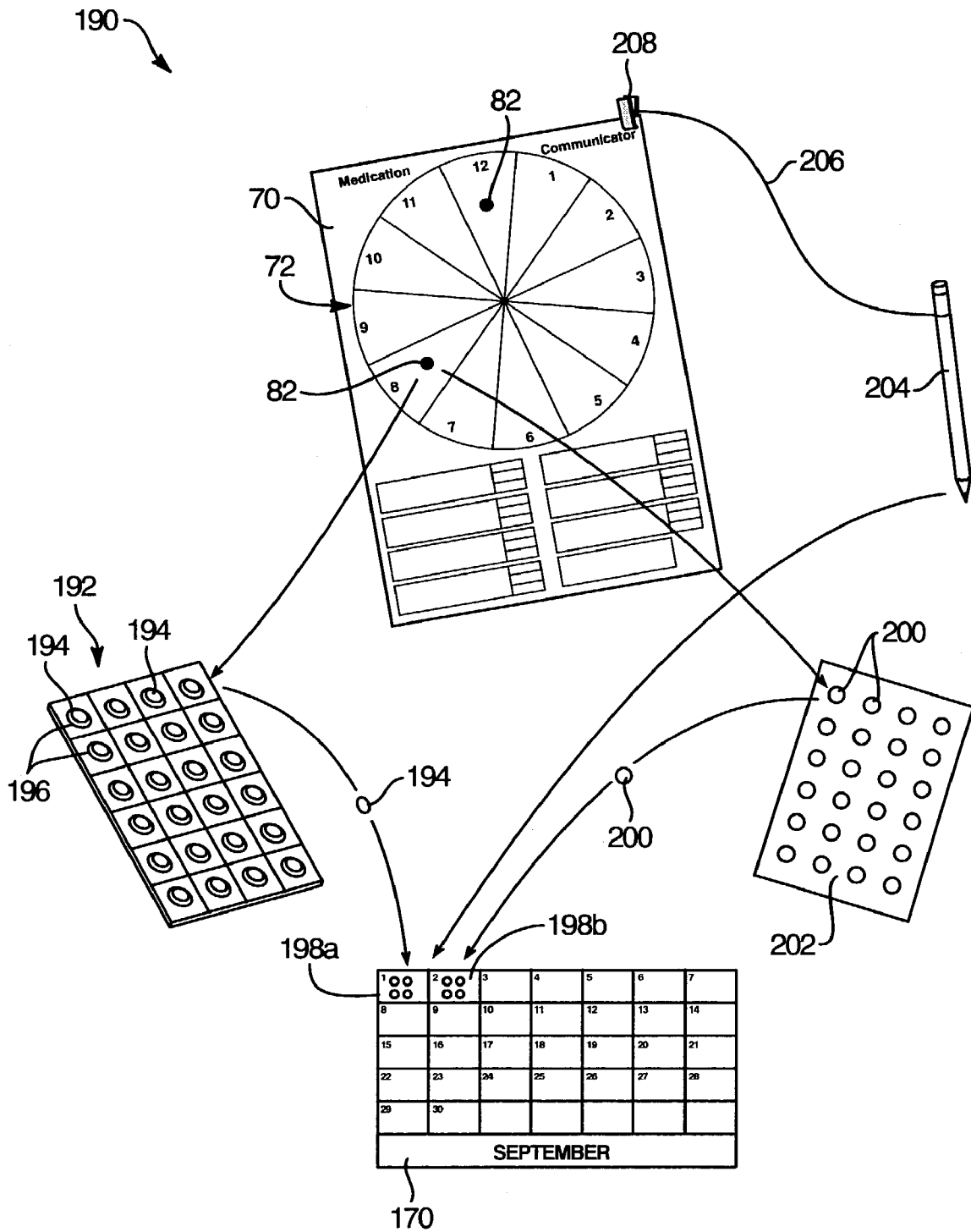

FIG. 12

MEDICATION REGIMEN COMMUNICATOR APPARATUS AND METHOD

BACKGROUND

1. The Field of the Invention

This invention relates to medication regimens prescribed by caregivers and, more particularly, to novel systems and methods for communicating medication regimens to clients or patients.

2. The Background Art

As the field of medicine continues to advance, particularly with the emergence of many new and effective drugs, the average life span of human beings continues to increase. In many cases, a regimen prescribed to a client or patient by a caregiver may include numerous drugs or medications. Each medication may have a distinct dosage, timetable for consumption, method of consumption, along with distinct instructions and warnings corresponding thereto. In certain instances, the timing or dosage of a particular drug may change from day to day. Moreover, medications may be administered by a professional, a relative, or the patient. As the number of medications in a selected regimen increases, so does the complexity of the medication regimen and the likelihood of error by a caregiver or patient. The error may occur in communication of or in compliance with instructions provided by a healthcare professional.

During the training of medical professionals, considerable emphasis is placed on the importance of maintaining strict accuracy in the administration of medications. Errors or misuse of drugs and medications may be dangerous to a patient, undermine their efficacy, and be extremely costly. Since many patient's medication regimens are administered at home on an out-patient basis, they are effectively self-supervised. Methods are needed to simplify and manage the communication, administration, and tracking associated with consumption of medications, so that they may be properly administered. Moreover, the ability of patients to cope with the complexity of overseeing a medication regimen may be further complicated by the patient's illness. Other factors that may undermine a patient's ability to correctly follow a medication regimen may include caregivers's or a patient's age (youth or seniority), education, language barriers, mental condition, sight or hearing impairment, and aptitude.

Tools are needed by medical professionals and professional caregivers to properly communicate with and educate both patients and caregivers about medication regimens. Charts currently used to convey this information may be useful to the caregivers themselves and others who can become familiar with them over time. However, such charts may be confusing to patients due to age (youth or seniority), education, language barriers, mental condition, sight or hearing impairment, and aptitude. Moreover, charts suitable for use may prove insufficient as teaching tools to properly educate patients and amateur caregivers.

What is needed is a chart system and process that are simplified and structured in a manner that may allow use of clear visual, iconic communication enabling substantially all patients and caregivers of varied age and medical condition to successfully follow a medication regimen.

What is further needed is a charting system and method to overcome language barriers by providing terminology, color, and symbology that can be more universally understood.

What is further needed is a charting system and method to serve as a successful teaching tool for medical professionals and professional caregivers to properly educate clients, ama-

teur caregivers, and patients of varied age and medical condition regarding a medication regimen.

What is further needed is a charting system and method that graphically illustrate to a client or patient proper times, medications, and dosages of a prescribed medication regimen.

Also needed is a system and method for tracking, by a patient, caregiver, or medical professional, the history of administration of medications. Doctors, nurses, and other need to know what has happened compared to what was prescribed. Patients need to know what was done. Anyone administering a medication may forget what has been done or whether it has been done as routines drag on and memories of events seem to blur together.

BRIEF SUMMARY AND OBJECTS OF THE INVENTION

In view of the foregoing, it is an object of the present invention to provide an apparatus and method for communicating a medication regimen, prescribed by a doctor or other caregiver, to a patient. A "medication communicator" chart, system, and method in accordance with the present invention may be used as a teaching tool to educate patients and to schedule events corresponding to a prescribed medication regimen. The "medication communicator" chart may include a scheduling graph having the shape of a 12-hour analog clock, 24-hour analog clock, or the like. This shape is used because it is universally understood and is more easily comprehended by the very young and elderly. In addition, the graphical nature of the analog clock may provide easier visualization over a typical rectangular chart or table. Moreover, poor eyesight is easily compensated by an analog dial, where written text may fail.

The scheduling graph may be divided into regions corresponding to each hour of a day. Fields, on the "medication communicator" chart may be receptive to labels communicating information corresponding to numerous medications in a prescribed medication regimen. Timing indicators may be applied to the regions of the scheduling graph to indicate consumption or application times of each of the medications.

Each of the medications may be readily distinguished from one another by assigning each medication a distinct color, pattern, symbol, texture, or the like. In addition, one embodiment "medication communicator" chart may include one or several fields receptive to labels printed with patient information, such as name, address, emergency contact information, identification number, if any, or any other desired patient information.

The "medication communicator" chart may include fields receptive to labels containing frequency information for consuming the medications. For example, in certain embodiments, an "every day" label may be applied to the chart to indicate that a patient is to take a medication every day. Likewise, "every other day" labels or labels designating specific days of the week may be applied to the chart to indicate when a medication is to be taken.

A label sheet may provide labels to be adhered to the "medication communicator" chart in accordance with the invention. The labels may include a pair of medication labels for each medication in the regimen. One label may be adhered to the "medication communicator" chart. The other corresponding label may be adhered directly to the packaging of the referenced medication. Each label may have the same color, pattern, symbol, texture, or the like, so that a selected medication may be referenced directly to the chart.

Each medication may include corresponding timing indicator labels characterized by the same color, pattern, symbol,

texture, or the like, as the medication label. These timing indicator labels may be adhered to the regions of the scheduling graph to indicate the time a selected medication is to be taken. In certain embodiments, the “medication communicator” chart may include calendars printed thereon to assist a patient in keeping track of the medication regimen.

In certain embodiments, the scheduling graph may be represented by two separate 12-hour analog clocks to represent the A.M and P.M, hours, respectively. This embodiment may help further clarify what medications are to be taken in the A.M. hours as opposed to the P.M. hours by applying the corresponding timing indicators to separate scheduling graphs. In this embodiment, timing indicator labels having an A.M. or P.M. designation may be eliminated. In selected embodiments, the A.M. and P.M. scheduling graphs may be identified by an A.M. and P.M. icon, respectively.

In certain embodiments in accordance with the invention, a system for record keeping may be used. For example, when a medication of a medication regimen is ingested or applied, a record-keeping label, pin, magnet, magnetic label, marker, or the like, may be used on a calendar to record consumption times of medications in the medication regimen. Thus, a patient may keep records of the regimen and provide feedback to a caregiver that a medication regimen has been executed correctly.

BRIEF DESCRIPTION OF THE DRAWINGS

The foregoing and other objects and features of the present invention will become more fully apparent from the following description, taken in conjunction with the accompanying drawings. Understanding that these drawings depict only typical embodiments of the invention and are, therefore, not to be considered limiting of its scope, the invention will be described with additional specificity and detail through use of the accompanying drawings in which:

FIG. 1 is a flow chart illustrating a generalized treatment process;

FIG. 2 is a schematic block diagram of an embodiment of a “medication communicator” chart in accordance with the present invention;

FIG. 3 is a schematic block diagram of one embodiment of a label sheet in accordance with the present invention;

FIG. 4 is a flow diagram of one embodiment of a method of using the present invention;

FIG. 5 is a flow diagram illustrating one embodiment of an education process in accordance with the present invention;

FIG. 6 is a flow diagram illustrating one embodiment of an assembly process in accordance with the present invention;

FIG. 7 is a schematic block diagram of an alternative embodiment of the “medication communicator” chart in accordance with the invention;

FIG. 8 is a schematic block diagram of labels that may be used in accordance with the “medication communicator” chart of FIG. 7;

FIG. 9 is a schematic block diagram of another alternative embodiment of the “medication communicator” chart in accordance with the invention;

FIG. 10 is a schematic block diagram of labels that may be used with the “medication communicator” chart illustrated in FIG. 9;

FIG. 11 is a schematic block diagram of another alternative embodiment of the “medication communicator” chart in accordance with the invention; and

FIG. 12 is a flow chart illustrating a method for maintaining records in a medication regimen in accordance with the present invention.

DETAILED DESCRIPTION OF THE PREFERRED EMBODIMENTS

It will be readily understood that the components of the present invention, as generally described and illustrated in the Figures herein, could be arranged and designed in a wide variety of different configurations. Thus, the following more detailed description of the embodiments of the system and method of the present invention, as represented in FIGS. 1 through 10, is not intended to limit the scope of the invention, but is merely representative of certain presently preferred embodiments of the system in accordance with the invention.

The term “patient” as used throughout the specification and claims, means any person or even an animal requiring management of a medication regimen. The terms “medicine” and “medication” as used throughout the specification and claims mean prescription and nonprescription drugs, vitamins, supplements, herbs, foods, bandages or other wraps, first aid devices, cleaning solutions, and the like. The term “caregiver” as used throughout the specification and claims means any doctor, physician, nurse, medical practitioner, family member, individual, patient, or and the like responsible for adherence to a medication regimen.

The embodiments of systems, methods, and devices in accordance with the invention will be best understood by reference to the drawings, wherein like parts are designated by like numerals throughout.

Referring to FIG. 1, a treatment process 10 may typically be initiated by either a regular checkup 12 of a patient or by a health complaint 14 initiated by a patient. As a result, an examination 16 of the patient may be performed by a doctor or caregiver. The examination 16 may result in an analysis 18 or a diagnosis 18 by a health professional. Depending on the result of the analysis or diagnosis 18, a doctor may prescribe a particular regimen 20 to the patient. For some over-the-counter medications, any caregiver may establish a regimen. However, a medical professional is more likely to do so. This regimen 20 may include either actions 22, medication 24, or a combination thereof 22, 24.

If medication 24 is prescribed, the prescription may include timing information 26 for ingesting or applying the prescribed medication, a required dosage 28 of the prescribed medication, a duration 30 for taking the prescribed medication, and information on the actual composition 32 being prescribed.

Once a medication 24 or action regimen 22 is prescribed, a caregiver may need to communicate 34 or educate 34 this regimen 20 to the patient or to a nonprofessional caregiver. The communication 34 or education process 34 may be facilitated by the use of selected tools 36. These tools 36 may assist a patient or client in executing 58 a regimen, or may help a caregiver in actually verifying 60 that the medical regimen has been executed correctly. Tools 36 may include various visual learning tools and techniques 38.

Other factors that may be important in implementing effective tools 36 to communicate or educate 34 a patient may include cost 40, ease of use 42 of the tool 36, as well as other patient considerations 44. By patient considerations 44 is meant taking into account factors that may determine if a tool 36 is successful at communicating or educating a patient. These may include a patient’s age 46, education 48, language 50, mental condition 52, sight or hearing impairment 54, aptitude 56, or the like. An effective tool 36 may be effective in overcoming any or all of these communication barriers 46, 48, 50, 52, 54, 56.

Once a regimen has been successfully communicated 34, a patient or client may need to actually follow 58 or execute 58

5

the regimen without supervision or with nonprofessional supervision. Thus where a patient is mentioned herein, a typically nonprofessional caregiver (or possibly other caregiver) may execute appropriate actions. Once the regimen has been executed **58**, a caregiver may need to verify **60** that the regimen has been properly executed. This may require providing feedback **62** or results **62** to a caregiver.

After receiving feedback **62** that a regimen **20** has been properly executed, if the patient's condition has not improved at a test **62**, the caregiver may choose to perform another examination **16** and prescribe another regimen **20**. If the patient's condition has improved according to the test **62**, but the patient's condition remains uncured, then the caregiver may again choose to perform another examination **16** and prescribe another regimen **20**. However, if the condition has improved at test **62** and the condition has been successfully treated and cured in the patient, then the prescribed regimen may be ended **68**.

Referring to FIG. 2, a "medication communicator" chart **70** may include a scheduling graph **72** to display scheduling information related to the medication regimen **24** of a patient or client. In certain embodiments, the scheduling graph **72** may be presented in the form of a twelve-hour analog clock. The twelve-hour analog clock may be used because it is universally understood and because it has become a worldwide standard. This may prove particularly important in communicating regimen **20** information to a young or elderly patient, or if a language barrier is present.

The scheduling graph **72** may be divided into regions **74** to produce a plurality of scheduling fields **74** so that different medications of a medication regimen **24** may be scheduled. Each scheduling field **74** may correspond to a time **76** indicating when the selected medication is to be ingested or applied by the patient. As illustrated, the scheduling graph **72** is represented by a twelve-hour analog clock. However, in other selected embodiments, a twenty-four hour analog clock may also be used. The "medication communicator" chart **70** may be printed on a variety of substrates including, but not limited to, paper, cardboard, laminate materials, glass, metal, plastics, and the like.

The "medication communicator" chart **70** may further include a plurality of medication fields **78**, each corresponding to a distinct medication in a medication regimen **24**. Each of the medication fields **78** may include notes and administration comments pertaining to a particular medication. For example, notes may include the strength of the medication and directions from the caregiver related to using the particular medication.

The "medication communicator" chart **70** may further include a patient information field **80** which may include desired patient information such as the patient's name, identification number if needed, address, emergency contact information, as well as other desired information. Each of the medication fields **78** may include corresponding fields **82** where timing information may be located. These spaces **82** may contain labels which indicate the timing or frequency with which a particular medication should be used. For example, a field **82a** may, for example, contain or include a label that informs the patient that a medication should be taken every day, every other day, or on selected days of the week. In addition, the "medication communicator" chart **70** may include a plurality of fields **78** to list each of the medications of a medication regimen **24**.

Because of the clock-like layout of certain embodiments of the "medication communicator" chart **70**, the chart **70** may be more easily understood by patients of all ages **46**, particularly the young and elderly, or of disparate educations **48**, lan-

6

guages **50**, mental conditions **52**, or aptitudes **56**. Because of the graphical layout **72** of the "medication communicator" chart **70**, medication regimen information may be more easily communicated by a caregiver to a patient or client. Moreover, because of the clock-like layout of the "medication communicator" chart **70**, a patient or client may be able to easily understand the times a particular medication is to be taken by simply referencing the chart with the time on a normal twelve-hour analog clock.

The "medication communicator" chart **70** may be used to schedule medications of a prescribed medication regimen **24**. However, one of ordinary skill in the art will be able to recognize that the chart **70** may be used to schedule not only medication **24**, but also actions **22**, or compliance with other instructions. In addition, the chart **70** may be used outside of the medical industry for many types of event scheduling. The color, pattern, symbol, or texture coding may be used in numerous applications to provide a simple, easy-to-follow, universally understood, scheduling system.

Referring to FIG. 3, a label sheet **81** may include a plurality of labels **81** which may be applied to a "medication communicator" chart **70**. For example, A.M. timing indicator labels **82** may be applied to the scheduling graph **72** to indicate when medications are to be taken by a patient or client in the "A.M." hours. Likewise, P.M. timing indicator labels **83** may also be applied to a scheduling graph **72** to indicate when medications are to be taken in the "P.M." hours. For example, if a medication is to be taken by a patient at 8:00 o'clock A.M., a label **82** may be applied to the space **74b**. However, if a medication is to be taken at 8:00 o'clock P.M. in the evening, a label **83** may be applied to the scheduling field **74b**. Likewise, the other labels **82**, **83** may be applied to the various fields **74** of the scheduling graph **72** to indicate other times when medications are to be taken or applied by a patient.

The label sheet **81** may also include a plurality of medication labels **84a**, **84b** to provide information related to a particular medication. One medication label **84a** may be applied to the "medication communicator" chart **70** in the medication field **78a**. A second medication label **84b** may be applied directly to the packaging or enclosure of a particular medication. In addition, if syringes or other implements are used to dispense or apply a particular medication, measurement labels **88** may be used to indicate the measure, amount, etc. of medication to be dispensed. In addition, timing indicator labels **90** may be provided in order to indicate to a patient the timing or frequency with which to take a particular medication.

For example, if a medication is to be taken every day, an "every day" label **90a** may be used. However, if a particular medication is to be taken every other day, an "every other day" **90b** label may be used. Likewise, if a medication is to be taken on some other day of the week, then labels **90c**, **90d**, **90e**, **90f**, **90g**, **90h**, **90i** may be used to indicate the other days of the week. Thus a label set **92a** may be used to provide information to client regarding a particular medication. The label set **92a** may be identified by a particular color, symbol or pattern to identify a particular medication. In other embodiments, a particular texture may be used to help blind or sight-impaired patients to identify a particular medication. In the case that a patient is color-blind, a particular pattern or cross-hatching may be used to help the patient identify a particular medication.

In a similar manner, other label sets **92b**, **92c**, **92d**, **92e**, **92f**, **92g** may be assigned a different color, pattern, symbol, texture, or the like to identify other medications in a medication regimen **24**. The medication information labels **84** may be configured to attach to a wide variety of medication contain-

ers including, but not limited to, bottles, tubes, inhalers, packages, boxes, blister packs, syringes, and the like.

In addition, medication information may be printed on the labels **84** using common typewriters or software templates. A particular software template may be configured so that data may be entered directly into fields **84**, **94** of the label sheet **81** by a personal computer. In other embodiments, special software may be programmed so that data may be entered and then formatted to print on the labels **84**, **94**.

The label sheet **81** may also include one or a plurality of patient information labels **94a**, **94b**. These information labels **94a**, **94b** may include information corresponding to a particular patient such as name, identification number, address, emergency contact information, and the like. The labels **94a**, **94b** may then be removed from the label sheet **81** and applied to the “medication communicator” chart **70** in the field **80**.

Referring to FIG. 4, a caregiver may use a pair of “medication communicator” charts **70a**, **70b**. A first “medication communicator” chart **70a** may be prepared for the caregiver’s records. A second “medication communicator” chart **70b** may be prepared to assist the patient or client. Labels may be removed from the label sheet **81** and applied to the “medication communicator” chart **70** according to a medication regimen. For example, a timing indicator label **82** may be removed from the label sheet **81** and applied to the “medication communicator” chart **70a** to indicate that a particular medication is to be taken at 12:00 o’clock A.M.

Likewise, in another example, a timing indicator label **82** may be removed from the label sheet **81** and applied to the “medication communicator” chart **70a** to indicate that a medication is to be taken or applied at 8:00 o’clock A.M. Likewise, if a medication is to be taken in the evening, one of the labels **83** may be applied to the “medication communicator” chart **70a** in order to indicate what time in the evening the medication is to be taken.

In a similar manner, a medication label **84a** may be removed from the label sheet **81** and applied to the “medication communicator” chart **70a** to provide information pertaining to a first medication in a medication regimen **24**. A second medication label **84** may be removed from the label sheet **81** and may be applied to a particular medication **96**, such as a bottle **96** of prescription drugs. The prescription medication **96** may already include an information label **98** containing information pertaining to the medication. The medication label **84** may be adhered to the medication **96** such that the label does not hide or cover up information contained on the label **98**.

In certain embodiments, the label **84** may be clear in order not to hide the inscription on the label **98**. If a syringe **100**, cup, spoon, or other implement **100** is to be used to dispense a particular medication, a measurement label **88** may be removed from the label sheet **81** and applied to the implement **100** or syringe **100** to indicate to the patient a particular measurement or grade to fill the syringe **100** or implement **100**. In a like manner, a patient information label **94** may be imprinted with desired patient or client information and may be removed from the label sheet **81** and applied to the “medication communicator” chart **70a**.

Referring to FIG. 5, while continuing to refer generally to FIGS. 1 through 4, an education process **102** may include preassembling **104** a first “medication communicator” chart. A preassembly process **104** may include first applying **106a** a client or patient information label **94** to the chart **70**, applying **108a** medication labels **84a** to the chart **70**, applying **109** timing labels **90** to the chart indicating the days of the week, and applying **110** timing labels **82**, **83** to the chart **70** indicating particular times of day.

A second step **112** may include partially assembling **112** a second. “medication communicator” chart **70**. The chart **70** may be partially assembled **112** by first applying **106b** client or patient information **94** to the chart **70** and then applying **108b** medication labels **84** to the chart **70**. A caregiver may then take the first preassembled “medication communicator” chart and the second partially assembled chart and display **114** both “medication communicator” charts **70** in front of a particular client or patient.

The assembly of the second “medication communicator” chart **70** may then be completed **116** while the client or patient observes. This may include first applying **118** timing labels **90** to the chart **70** indicating the days of the week, applying **120** timing labels **82**, **83** to the chart indicating the times of day each medication is to be taken, and then indicating **122** the time on an actual clock in order to help the patient be visually reminded to remember when to take the medication. Thus, the client or patient may observe the assembly of the second “medication communicator” chart **70** by the caregiver. This may assist the learning process and provide a visual aid that may be more easily remembered.

As a caregiver is completing the second chart **70**, the caregiver may show **124** the client or patient each medication as the timing is designated on the chart **70**. This may include showing **126** the dosage to the client, as well as showing **128** the method of preparation, application, or consumption of the medication. If an implement (e.g. syringe) **100** is needed to dispense a particular medication, the measurement may be shown on the grading of the implement **100** at this time using the labels **88**. This may include showing **132** a patient how to use the implement **100**, labeling **134** the implement **100** with the correct medication information, and using the labels **88** to indicate **136** the correct dosage of medication. Once the medication regimen **24** is properly demonstrated to the client or patient, the caregiver may then use various methods to verify that the patient understood the regimen **24**.

Referring to FIG. 6, an assembly process **140** of a “medication communicator” chart **70** may include initially determining **140** a medication regimen **24**. Colors, symbols, patterns, textures, or other identifiers may be assigned **144** to each medication in the medication regimen **24**. Any and all writing and coloring may be done in braille. After an identifier is assigned **144**, medication information may be printed on the labels of the label sheet **81**. This may include information such as the name **148** of the patient, the name **150** of the medication or composition, times **152** to take the medication, the dosage **154** of the medication to be ingested or applied, directions **156** on taking the medication, and the like.

Once the proper information is printed on the labels **84**, the information labels **84** may then be applied **158** to each of the medications in the medication regimen **24**. Corresponding labels **84** may then be applied **160** to the “medication communicator” chart **70**. Once the information labels **84** are applied **160** to the “medication communicator” chart **70**, the timing labels **82**, **83** may then be applied **162** to the chart **70**. This may include applying **164** the labels **82**, **83** such that they indicate **164** the times of day, and applying the labels **90** indicating **166** the particular days of the week that the medication is to be taken. Once the timing labels **82**, **83**, **90** are applied **162** to the chart **70**, measurement labels **88** may be applied **168** to any syringes **100**, if used.

Referring to FIG. 7, in an alternative embodiment, the “medication communicator” chart **70** may include one or a plurality of calendars **170a**, **170b**, **170c** indicating even and odd days **172a**, **172b**, **172c** of the week. The even and odd days **172a**, **172b**, **172c** may be used to schedule when particular medications are to be taken.

For example, referring to FIG. 8, labels **92** assigned to a particular medication, may include an “every day” label **90a**, an “every odd day” label **90b**, and an “every even day” label **90c**. This method may assist in eliminating confusion caused by the “every other day” label **90b** described in FIG. 3. For example, under certain circumstances, a patient may forget to keep track of what days correspond to “every other day.” With respect to the “every odd day” label **90b**, a patient or client may simply refer to the calendars **170a**, **170b**, **170c**, and take a selected medication on the odd days of the months **170a**, **170b**, **170c**. Likewise, with respect to the “every even day” label **90c**, a patient or client may simply refer to the calendars **170a**, **170b**, **170c** and take a selected medication on the even days of the months **170a**, **170b**, **170c**. Alternatively, the specific administration days of a week may be named, such as, for example, Monday and Thursday of each week.

Referring to FIG. 9, in selected embodiments, the “medication communicator” chart **70** may include two scheduling graphs **72a**, **72b**. A first scheduling graph **72a** may be used to establish an A.M. medication schedule and second scheduling graph **72b** may be used to establish a P.M. medication schedule. This may help eliminate confusion caused by using one scheduling graph **72** to represent both A.M. and P.M. hours. The two scheduling graphs **72a**, **72b** may continue to represent a standard twelve-hour clock face, but may be effective to schedule events over a twenty-four hour day.

In certain embodiments, an A.M. icon **180** may be used to identify a first scheduling graph **72a** and a P.M. icon **182** may be used to identify a second scheduling graph **72b**. The icons **180**, **182** may be located anywhere on the “medication communicator” chart **70** as long as they may be correctly identified with the corresponding scheduling graphs **72a**, **72b**. In selected embodiments, the icons **180**, **182**, may be located outside or inside the scheduling graphs **72a**, **72b**.

Accordingly, referring to FIG. 10, the timing indicator labels **82**, **83** illustrated in FIGS. 3 and 8 may simply be represented by labels **184** lacking any A.M. or P.M. designation. These labels **184** may then be applied to either of the A.M. or P.M. scheduling graphs **72a**, **72b** illustrated in FIG. 9 to schedule a selected event. By using two scheduling graphs **72a**, **72b**, any identifiers designating the labels **184** as either A.M. or P.M. labels **82**, **83** are unnecessary.

Referring to FIG. 11, the “medication communicator” chart **70** may include both a pair of scheduling graphs **72a**, **72b**, as well as calendars **170a**, **170b**, **170c**, to identify the days **172a**, **172b**, **172c** of the month. This chart **70** may provide the advantages of the chart **70** illustrated in FIG. 7 as well as the chart **70** illustrated in FIG. 9. A client or patient may easily identify events over a complete twenty-four day, eliminating the need for A.M. and P.M. timing labels **82**, **83**. In addition, the calendars **170a**, **170b**, **170c**, may aid the patient or client in identifying odd, even, or specified days of the week to take a selected medication. As was previously described with respect to FIG. 9, A.M. and P.M. icons **180**, **182** may be used to identify each scheduling graph **72a**, **72b**.

With respect to FIG. 12, a method for maintaining records **190** of the execution of a medical regimen **24** may be used in accordance with the present invention. For example, in certain embodiments, a timing label **82** may be used to identify a time for taking a selected medication. A medication **196** may be contained in a blister pack **192** or other suitable packaging **192**. In one selected embodiment, labels **194** may be used to cover each pill or tablet **196** in the blister pack **192**. When a pill or tablet **196** is removed from the blister pack **192**, the label **194** may be first removed from the blister pack. This label **194** may then be applied to a calendar **170** in a field indicating a particular day **198a**. As each successive pill or

tablet **196** is removed from the blister pack **192**, the labels **194** may be applied to the calendar **170**. Thus, a method of record keeping **190** may be provided to keep track of a client’s or patient’s actual administration of a medication regimen **24**.

In another embodiment, a record label sheet **202** may be used to track a client’s or patient’s medication regimen **24**. For example, when a medication is taken corresponding to an event indicated by a timing label **82**, a sticker or label **220** may be removed from the label sheet **202** and applied to the calendar **170**. Each time a medication is ingested or applied, another label or sticker **200** may be applied to a particular day **198** of the calendar **170**. In certain embodiments, reusable indicators **200**, such as magnetic labels or reusable tacks or pins, may be used to indicate when a medication has been taken on the calendar **170**. Likewise, the calendar **170** may be constructed from a variety of materials including paper, cardboard, wood, laminates, plastics, a bulletin board material, or some other like material. In another embodiment, the labels **200** may include a particular texture such as braille which might be used by a blind or sight-impaired patient.

In another embodiment, a record marker **204** may be used to keep track of events on the “medication communicator” chart **70**. When a medication is taken, the record marker may be used to annotate the event on the calendar **170**. In certain embodiments, the record marker may be a dry-erase marker **204** and the calendar **170** may be a dry-erase white board. The marker **204** may also include a tether **206** to tie the marker to the “medication communicator” chart **70**, or the calendar **170**.

The present invention may be embodied in other specific forms without departing from its essential characteristics. The described embodiments are to be considered in all respects only as illustrative, and not restrictive. All changes that come within the meaning and range of equivalency of the description are to be embraced within their scope.

What is claimed and desired to be secured by United States Letters Patent is:

1. A method for communicating a medical regimen to a patient, the method comprising:

- providing a scheduling device comprising
 - a scheduling graph fixed to a supporting substrate,
 - a reference chart positioned on the substrate in close proximity to the scheduling graph,
 - the scheduling graph having a shape corresponding to a clock face representing at least one of a 12-hour, circular, analog clock and a 24-hour, circular, analog clock,
 - the scheduling graph, further comprising markings spaced to divide an area thereof into regions corresponding to hours of a day,
 - the scheduling graph further being fixed to be non-rotating with respect to a support underlying the scheduling graph,
 - the reference chart further comprising a plurality of fields sized and shaped to receive therein labels affixed thereto,
 - the reference chart, wherein each field of the plurality of fields further comprises an information region and at least one frequency region corresponding thereto, the information region and frequency region being distinguished from one another by at least one of size and shape,
- providing a sheet comprising a plurality of sets of labels, each set thereof comprising
 - members, each being a label selectively removable from the sheet and comprising a material adherent to at least one of the scheduling graph and the reference chart,

11

a visual feature unique to the each set and shared by the members of the set,
 the members, further comprising an information label having a surface prepared to receive an identification of a medication, and shaped to match the shape of the information region of a field of the reference chart,
 the members, further comprising a plurality of frequency labels, each specifying at least one day, being shaped to match the shape of the frequency region of a field of the reference chart and distinct from the shape of the information label,
 the members, further comprising a plurality of timing labels, each timing label being distinguished from both the information label and each of the frequency labels by at least one of size and shape; and
 providing instructions to a caregiver of the patient, effective to prepare the sheet, imprinted with information, reflecting the medical regimen, on at least one of the sets of labels.

2. The method of claim 1, wherein the providing instructions further comprises providing software effective to imprint the sheet.

3. The method of claim 2, wherein the providing instructions further comprises providing software comprising a template and executable to receive data entered by the caregiver for imprinting on labels of the sheet.

4. The method of claim 1, wherein the providing instructions further comprises providing software comprising a template and executable to receive data entered by the caregiver for imprinting on labels of the sheet.

5. A method for communicating a medical regimen to a patient, the method comprising:
 obtaining a scheduling device comprising
 a scheduling graph fixed to a supporting substrate,
 a reference chart positioned on the substrate in close proximity to the scheduling graph,
 the scheduling graph having a shape corresponding to a clock face representing at least one of a 12-hour, circular, analog clock and a 24-hour, circular, analog clock,
 the scheduling graph, further comprising markings spaced to divide an area thereof into regions corresponding to hours of a day,
 the scheduling graph further being fixed to be non-rotating with respect to a support underlying the scheduling graph,
 the reference chart further comprising a plurality of fields sized and shaped to receive therein labels affixed thereto,
 the reference chart, wherein each field of the plurality of fields further comprises an information region and at least one frequency region corresponding thereto, the information region and frequency region being distinguished from one another by at least one of size and shape,
 obtaining a sheet comprising a plurality of sets of labels, each set thereof comprising
 members, each being a label selectively removable from the sheet and comprising a material adherent to at least one of the scheduling graph and the reference chart,
 a visual feature unique to the each set and shared by the members of the set,
 the members, further comprising an information label having a surface prepared to receive an identification of a medication, and shaped to match the shape of the information region of a field of the reference chart,

12

the members, further comprising a plurality of frequency labels, each specifying at least one day, being shaped to match the shape of the frequency region of a field of the reference chart and distinct from the shape of the information label,
 the members, further comprising a plurality of timing labels, each timing label being distinguished from both the information label and each of the frequency labels by at least one of size and shape; and
 preparing the sheet, imprinted with information, reflecting the medical regimen, on at least one of the sets of labels.

6. The method of claim 5, wherein the preparing further comprises obtaining software effective to imprint the sheet in accordance with instructions from a caregiver to the patient.

7. The method of claim 6, wherein the preparing further comprises running, on a computer, the software and imprinting labels of the sheet.

8. The method of claim 7, wherein the software further comprises a template and is executable to prompt the caregiver and receive data entered by the caregiver in accordance with the template.

9. The method of claim 5, wherein the preparing further comprises running, on a computer, the software and imprinting labels of the sheet.

10. The method of claim 9, wherein the software further comprises a template and is executable to prompt the caregiver and receive data entered by the caregiver in accordance with the template.

11. The method of claim 4, further comprising:
 imprinting an information label of a first set of the plurality of sets with information identifying a medication; and
 removing from the sheet from the first set the information label;
 placing the information label on the information region of a first field of the plurality of fields on the reference chart.

12. The method of claim 11, further comprising:
 removing from the sheet, from the first set, a first frequency label; and
 adhering the first frequency label on a frequency region of the first field.

13. The method of claim 12, further comprising:
 removing from the sheet, from the first set, a first timing label; and
 adhering the first timing label on a region of the scheduling graph.

14. The method of claim 5, wherein the visual feature is a property selected from the group consisting of a color, a pattern, a symbol, a word, and a texture.

15. An apparatus for communicating a medical regimen to a patient, the apparatus comprising:
 a scheduling device comprising
 a scheduling graph fixed to a supporting substrate,
 a reference chart positioned on the substrate in close proximity to the scheduling graph,
 the scheduling graph having a shape corresponding to a clock face representing at least one of a 12-hour, circular, analog clock and a 24-hour, circular, analog clock,
 the scheduling graph, further comprising markings spaced to divide an area thereof into regions corresponding to hours of a day,
 the scheduling graph further being fixed to be non-rotating with respect to a support underlying the scheduling graph,

13

the reference chart further comprising a plurality of fields sized and shaped to receive therein labels affixed thereto,

the reference chart, wherein each field of the plurality of fields further comprises an information region and at least one frequency region corresponding thereto, the information region and frequency region being distinguished from one another by at least one of size and shape; and

a sheet comprising a plurality of sets of labels, each set thereof comprising

members, each being a label selectively removable from the sheet and comprising a material adherent to at least one of the scheduling graph and the reference chart,

a visual feature unique to the each set and shared by the members of the set,

14

the members, further comprising an information label having a surface prepared to receive an identification of a medication, and shaped to match the shape of the information region of a field of the reference chart,

the members, further comprising a plurality of frequency labels, each specifying at least one day, being shaped to match the shape of the frequency region of a field of the reference chart and distinct from the shape of the information label,

the members, further comprising a plurality of timing labels, each timing label being distinguished from both the information label and each of the frequency labels by at least one of size and shape.

16. The apparatus of claim 15, further comprising instructions directed to a caregiver of the patient, effective to prepare the sheet, imprinted with information, reflecting the medical regimen, on at least one of the sets of labels.

* * * * *